

**High Performance:** These antennas provide 6dBd, wide band performance.

**Rugged and weatherproof:** The construction of our heavy duty yagis feature 1"aluminum U channel with 3/8" solid elements. All exposed areas are coated with UV polyester. The balun assembly is filled and sealed with elastomeric thermoplastic.

**Lightweight and Durable:** These antennas are easily installed by one person.

**Termination Options:**

**Type D:** Direct N connection to the balun.

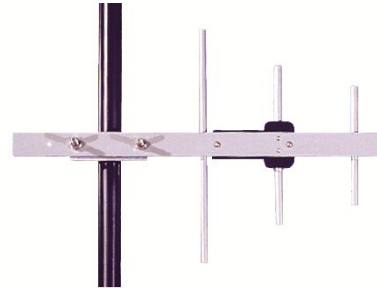

**ELECTRICAL SPECIFICATIONS:**

**GAIN:** 6.0dBd F/B 15dB  
**FREQUENCY:** 746-960MHz <2:1 VSWR  
**VERT BEAMWIDTH:** 70°  
**HORIZ BEAM WIDTH:** 90°  
**RATING :** 300 watts, 50 ohms impedance

**MECHANICAL SPECIFICATIONS:**

**MATERIAL:** 1" (2.54cm) aluminum U channel  
boom 3/8" (9.5mm) solid elements  
**FINISH:** UV inhibited polyester coat  
**LENGTH:** 18" (46cm)  
**WEIGHT:** <4 lbs. (1.8kg)  
**MOUNT:** 2 3/8" (6cm) mast, stainless hardware  
**FLAT PLATE AREA:** .147 ft<sup>2</sup>  
**WIND RATING:** 125 MPH (201kph)  
**WIND LOAD:** 8.8 lbs. (3.9kg)

**Horizontal Pattern**

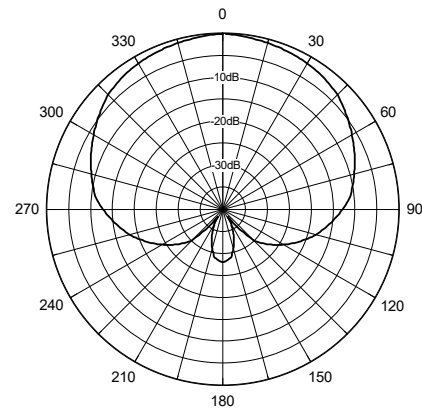

**Verical Pattern**

