

## LMW-3XX Installation Instruction

### Installation Steps:

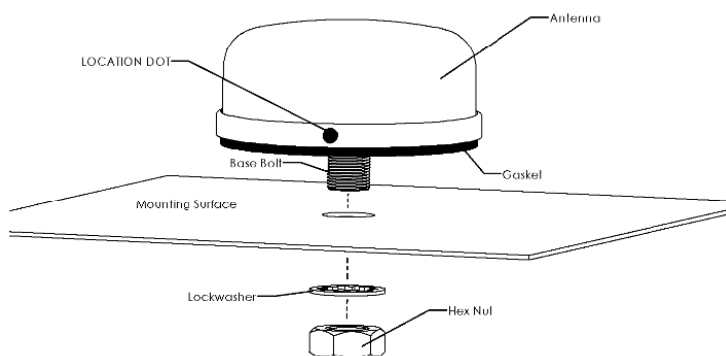

*Surface Mount*

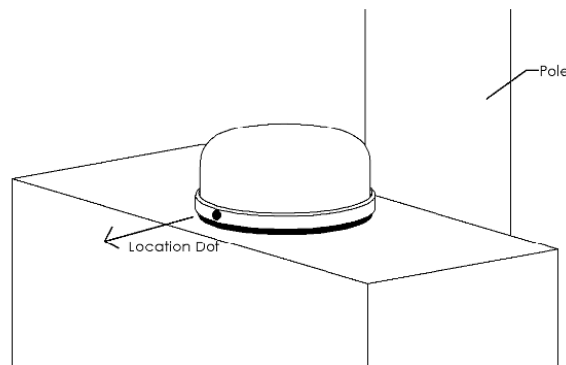

*Utility Box Mount*

- Drill a 5/8" (15.9mm) diameter hole through the mounting surface.
- (1 sq-ft [30.5cm] ground plane recommended)
- Remove all the paper from the gasket.
- Feed the cable(s) and base bolt through the hole.
- **OPTIONAL:** If additional sealing is required, a bead of silicone can be applied around the circumference of the gasket.

- For models with GPS or GNSS Make sure the location dot marker is faced away from any vertical obstructions.
- Attach the lock washer, hex nut, & plastic spacers (if supplied).
- Tighten nut to 5 lb./ft. (6.8 Nm).
- **NOTE:** DO NOT overtighten.

**NOTE:** If the underside of the base bolt is exposed, sealing is around the cable exit required.

**ATTENTION:** Always wear safety glasses and follow the proper safety practices when installing this antenna.



[Terms and Conditions](#)



Toll Free: 1-800-648-2800  
Phone: 1-847-671-6690  
Fax: 1-847-250-5120  
Email: [info@mobilemark.com](mailto:info@mobilemark.com)



Phone: +44 1543 459555  
Fax: +44 1543 459545  
Email: [enquiries@mobilemarkeurope.co.uk](mailto:enquiries@mobilemarkeurope.co.uk)



[Mobilemark.com](http://Mobilemark.com)

950-036-9-001-0318/DR: SM/APP: RP/REV. B