

CLTM Installation Instructions

INSTALLATION STEPS:

- Attach hex nut and mounting bracket to the antenna

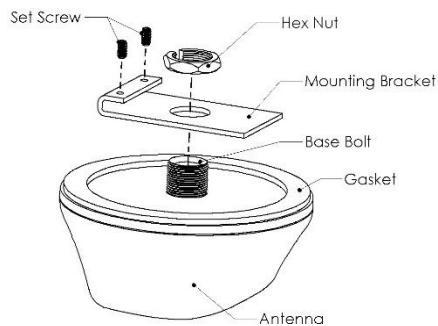

NOTE: A small notch may be required on the clamp side of the bracket

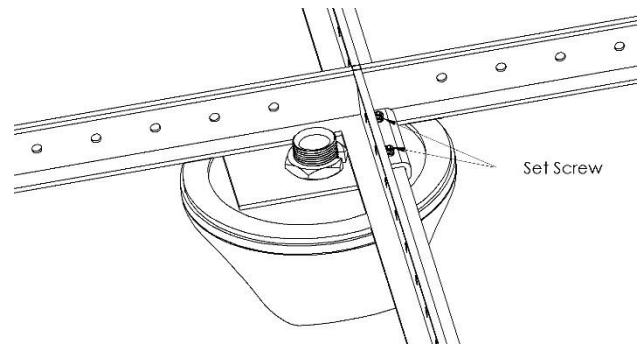

- Cut a 2"-2 ½" notch out of the corner of the ceiling tile
- Attach mounting bracket to suspension grid with supplied set screws
- Pull cables through the cut out on the ceiling tile and drop in place on the suspension grid
- **ATTENTION:** Always wear safety glasses and follow the proper safety practices when installing this antenna

WARRANTY

Mobile Mark, Inc. (Seller) warrants to Buyer that the products for a period of two years from the date of shipment will be free from defects of material and workmanship, and will be in accordance with specifications referred to herein. Seller's sole obligation under these warranties will be limited to either, at Seller's option and expense, repairing, or furnishing a replacement F.O.B. First point of shipment for the products or parts thereof which Seller reasonably determines do not conform with these warranties, and Buyer's exclusive remedy for breach of any of such warranties will be enforcement of such obligations of Seller. THE FOREGOING WARRANTIES ARE EXCLUSIVE AND IN LIEU OF ALL OTHER WARRANTIES OF MERCHANTABILITY, FITNESS FOR PURPOSE AND OF ANY OTHER TYPE, WHETHER EXPRESS OF IMPLIED. IN NO EVENT SHALL SELLER BE LIABLE FOR CONSEQUENTIAL DAMAGES, nor shall Seller's liability on any claims for damages arising out of or connected with the sales contract for the manufacture, sale, delivery or use of the products exceed the purchase price of the products. Any action for breach of warranty must be commenced within one year after the cause of action accrues.

1140 W. Thorndale Ave. · Itasca, IL 60143, USA · www.mobilemark.com
Toll free: 1-800-648-2800 (US & Canada) · Phone 1-847-671-6690 · Fax 1-847-250-5120
Moving Wireless Forward™