

LMW-3XX Installation Instructions

INSTALLATION STEPS:

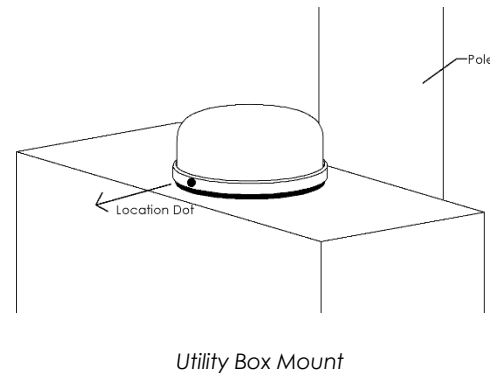
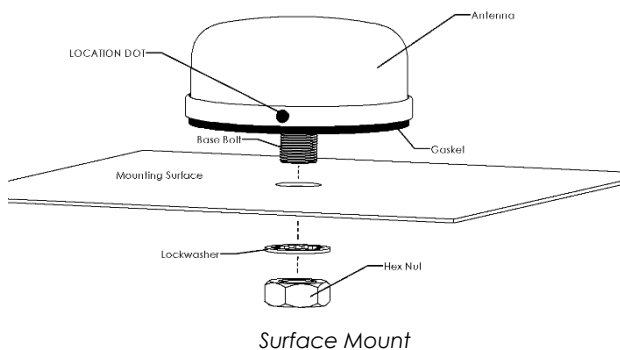

- Drill a 5/8" (15.9mm) diameter hole through the mounting surface.
(1 sq-ft [30.5cm] ground plane recommended)
- Remove all the paper from the gasket.
- Feed the cable(s) and base bolt through the hole.
- OPTIONAL: If additional sealing is required, a bead of silicone can be applied around the circumference of the gasket.

- For models with GPS or GNSS Make sure the location dot marker is faced away from any vertical obstructions.
- Attach the lock washer, hex nut, & plastic spacers (if supplied).
- Tighten nut to 5 lb./ft. (6.8 Nm).
NOTE: DO NOT overtighten.

NOTE: If the underside of the base bolt is exposed, sealing is around the cable exit required.

ATTENTION: Always wear safety glasses and follow the proper safety practices when installing this antenna.

WARRANTY

Mobile Mark, Inc. (Seller) warrants to Buyer that the products for a period of two years from the date of shipment will be free from defects in material and workmanship, and will be in accordance with specifications referred to herein. Seller's sole obligation under these warranties will be limited to either, at Seller's option and expense, repairing, or furnishing a replacement F.O.B. First point of shipment for the products or parts thereof which Seller reasonably determines do not conform with these warranties, and Buyer's exclusive remedy for breach of any of such warranties will be enforcement of such obligations of Seller. THE FOREGOING WARRANTIES ARE EXCLUSIVE AND IN LIEU OF ALL OTHER WARRANTIES OF MERCHANTABILITY, FITNESS FOR PURPOSE AND OF ANY OTHER TYPE, WHETHER EXPRESS OR IMPLIED. IN NO EVENT SHALL SELLER BE LIABLE FOR CONSEQUENTIAL DAMAGES, nor shall Seller's liability on any claims for damages arising out of or connected with the sales contract for the manufacture, sale, delivery or use of the products exceed the purchase price of the products. Any action for breach of warranty must be commenced within one year after the cause of action accrues.

www.mobilemark.com

US Tel: 1-847-671-6690 UK Tel: (+44) 1543 459555

Moving Wireless Forward®