

## PND10-700/2700 Installation Instructions

### INSTALLATION STEPS:

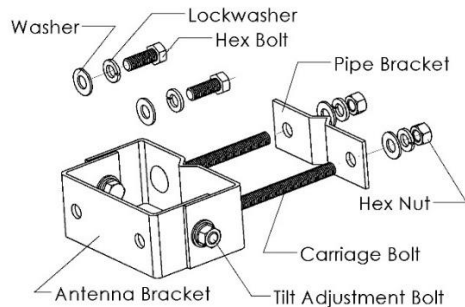

Shown: Mounting Kit and Hardware

- Attach the bracket to the rivet nuts on the back of the antenna with supplied hardware

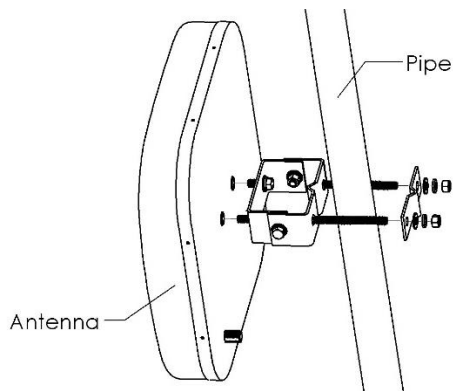

- Mounting kit can accommodate pipes 1"-2.5" (25.4mm-63.5mm) in diameter
- **ATTENTION:** Always wear safety glasses and follow the proper safety practices when installing this antenna.

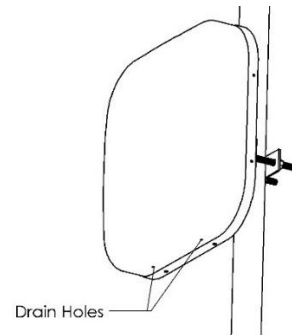

- Mount antenna with drain holes facing downward
- Loosen Tilt Adjustment Bolts to adjust antenna up or down, and then retighten

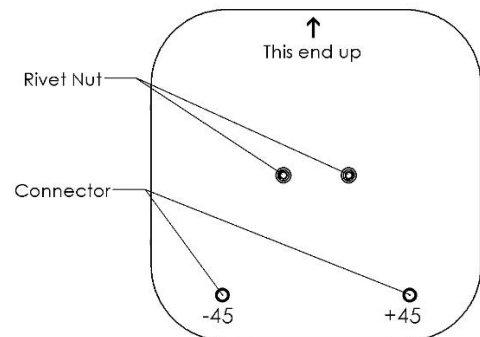

Shown: Back of antenna

- Tighten slant +/-45 antenna connectors to 5 lb./ft. (6.8 Nm)  
**NOTE:** DO NOT overtighten

**OPTIONAL:** For lightning/surge protection use Lightning Arrestor (ACC-TW-LP-005N) or, Gas Tube Surge Arrestor (ACC-GT-NFF-AL)

### WARRANTY

Mobile Mark, Inc. (Seller) warrants to Buyer that the products for a period of two years from the date of shipment will be free from defects of material and workmanship, and will be in accordance with specifications referred to herein. Seller's sole obligation under these warranties will be limited to either, at Seller's option and expense, repairing, or furnishing a replacement F.O.B. First point of shipment for the products or parts thereof which Seller reasonably determines do not conform with these warranties, and Buyer's exclusive remedy for breach of any of such warranties will be enforcement of such obligations of Seller. **THE FOREGOING WARRANTIES ARE EXCLUSIVE AND IN LIEU OF ALL OTHER WARRANTIES OF MERCHANTABILITY, FITNESS FOR PURPOSE AND OF ANY OTHER TYPE, WHETHER EXPRESS OR IMPLIED. IN NO EVENT SHALL SELLER BE LIABLE FOR CONSEQUENTIAL DAMAGES, nor shall Seller's liability on any claims for damages arising out of or connected with the sales contract for the manufacture, sale, delivery or use of the products exceed the purchase price of the products. Any action for breach of warranty must be commenced within one year after the cause of action accrues.**

1140 W. Thorndale Ave. · Itasca, IL 60143, USA · [www.mobilemark.com](http://www.mobilemark.com)

Toll free: 1-800-648-2800 (US & Canada) · Phone 1-847-671-6690 · Fax 1-847-250-5120

Moving Wireless Forward™