

Technical Specification

406-512 MHz 10.4dB Gain

HEAVY DUTY YAGI ANTENNA

High Performance: These antennas provide 10.4dBd, wide band performance.

Rugged and weatherproof: The construction of our heavy duty yagis feature 1"aluminum U channel with 3/8" solid elements. All exposed areas are coated with UV polyester. The balun assembly is filled and sealed with elastomeric thermoplastic.

Lightweight and Durable: These antennas are easily installed by one person.

Termination Options:

Type A: 12" Teflon pigtail with N connector.

Type B: Direct TNC connection to the balun.

Type D: Direct N connection to the balun.

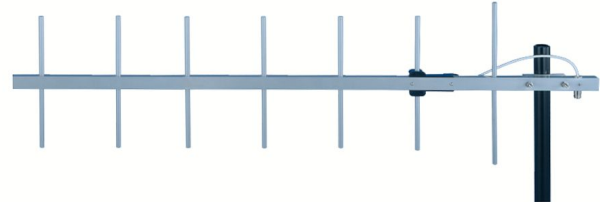

ELECTRICAL SPECIFICATIONS:

GAIN: 10.4dBd F/B 20dB

FREQUENCY:
 -A 406-430MHz <2:1 VSWR
 -B 430-450MHz <2:1 VSWR
 -C 450-470MHz <2:1 VSWR
 -D 470-490MHz <2:1 VSWR
 -E 490-512MHz <2:1 VSWR

VERT BEAMWIDTH: 50°

HORIZ BEAM WIDTH: 55°

RATING : 300 watts, 50 ohms impedance

MECHANICAL SPECIFICATIONS:

MATERIAL: 1" (2.54cm)aluminum U channel boom

3/8" (9.5mm)solid elements

FINISH: UV inhibited polyester coat

LENGTH: 43" (1m)

WEIGHT: <4 lbs. (1.8kg)

MOUNT: 2 3/8" (6cm)mast, stainless hardware

FLAT PLATE AREA: .42 ft²

WIND RATING: 125 MPH (201kph)

WIND LOAD: 25.5 lbs. (11.5kg)

Horizontal Pattern

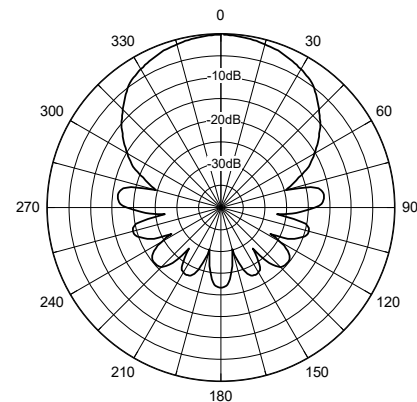

Vertical Pattern

